

ICS 23.120

P 48

National Standard of the People's Republic of China

GB/T 14294-2008

Replace GB/T 14294-1993, GB 13326-1991

Central-station Air Handling Units

组合式空调机组

(English translation)

Issued date:2008-11-04

Implementation date:2009-06-01

Issued by General Administration of Quality Supervision, Inspection and Quarantine of the

Contents

Foreword	1
1 Scope	1
2 Normative References.....	1
3 Terms and Definition.....	2
4 Classification and Mark.....	3
5 Materials	5
6 Requirements	5
7 Test Methods	8
8 Inspection Rules.....	13
9 labeling Packaging, Transportation and Storage	
10 Basic contents of product catalog and Instruction manual	
Appendix A (Normative) Air Flow Rate, air pressure and input electric power test methods of central-station air handling units.....	16
Appendix B (Normative) Field test methods of air flow rate, air pressure and input electric power of central-station air handling units.....	23
Appendix C (Normative) Test methods of air leakage rate of central-station air handling units	27
Appendix D (Normative) Test methods of deformation rate of central-station air handling units	29
Appendix E (Normative) Test methods of cooling capacity and heating capacity of central-station air handling units.....	31
Appendix F (Informative) Field test methods of cooling capacity and heating capacity of central-station air handling units.....	40

Foreword

SAC/TC143/SC4 is in charge of the English translation. In case of any doubt about the contents of English translation, the Chinese original shall be considered authoritative.

This standard shall replace GB/T 14294-1993 "Central-station Air Handling Units" and GB 13326-1991 "Sound Limit of Central-station air handling units".

There have been some significant changes in this national standard over GB/T 14294-1993 and GB 13326-1991:

Changes in performance indexes: external static pressure of the unit shall not be less than 90% of rated value under dry operating condition, and shall not be less than 85% of rated value under wet operating condition; the cooling capacity and heating capacity shall not be less than 95% of rated value, and the requirements on deformation rate of the casing, water flow rate and water resistance were added.

The unit's noise shall be determined according to air flow rate and total static pressure of the unit.

Changes in test methods: for cooling capacity and heating capacity test, the room air enthalpy potential method is added except for the duct ring air enthalpy potential method; the negative pressure device shall be added for unit air leakage rate; the unit air flow and air pressure test shall adopt duct pitot tube and multi-airflow nozzle method; and the deformation test shall be added and be divided into positive pressure test and negative pressure test.

Appendixes A, B, C, D and E are normative and Appendix F is informative.

This standard was proposed by the Ministry of Housing and Urban-rural Development of the People's Republic of China.

This standard is under the jurisdiction of the National Technical Committee 143/SC4 on HVAC of Standardization Administration of China.

This standard replaces the following editions in turn:

GB/T 14294-1993.

GB 13326-1991.

Central-station Air Handling Units

1 Scope

This standard specifies the terms and definition, classification and mark, materials, requirements, test methods, inspection rules, marking, packing, transporting and storing, product sample and the basic contents of product specification of central-station air handling units ("units" for short).

This standard is applicable to the units that have the assembling functional sections and are able to realize at least one of the following air handling functions such as delivery, mixing, heating, cooling, dehumidification, humidification, filtration, noise elimination and heat recovery.

Those units which take brine, glycol and direct-expansion coil as the coolant as well as the ones adopting electric heater may refer to the standard.

This standard is not applicable to air conditioner with self-equipped cool and heat source fan-coil unit and fan heater unit.

2 Normative References

The provisions in following documents which through reference in the text, constitute provisions of this standard. For dated references, subsequent amendments, or revisions, of any of these publications do not apply to this standard. However, parties to agreements based on this standard are encouraged to investigate the possibility of applying the most recent editions of the normative documents indicated below. For undated reference, the latest edition of the normative document referred to applies.

- GB/T 1236-2000 *Industrial Fans-Performance Testing Using Standardized Airways*
GB/T 2624.3-2006 *Measurement of Fluid Flow by Means of Pressure Differential Devices Inserted in Circular Cross-section Conduits Running Full-Part 3: Nozzles and Venturi Nozzles*
GB/T 9068-1988 *Determination of Sound Power Levels for Noise Emitted by Heating Ventilating and Air Conditioning Equipment-Engineering Method*
GB/T 14296 *Air Cooling and Air Heating Coils*
GB/T 16803 *Equipment of Heating, Ventilating, air Conditioning and Air Cleaning Terminology*
JB/T 9064 *Pressure Test and Sealed Examine for Coil*
JG/T 21-1999 *Test Method for Determining the Performance of Air Cooling and Air Heating Coils*

3 Terms and Definition

For the purpose of this document, the terms and definitions below and given in GB/T 16803 apply.

3.1

Central-station air handling units

It refers to a kind of air handling unit assembled by various air handling functional sections. It is applicable to the air-conditioning system with air side resistance larger than or equal to 100Pa.

3.2

Functional section of units

It refers to the unit having one or several kinds of handling functions on air. The unit functional sections include such functions as air mix, flow equalization, filtration, cooling, primary heating and reheating, dehumidification, humidification, air supply fan, air return fan, water spraying, noise elimination and heat recovery.

3.3

Rated air flow rate

It refers to the air volume flow rate passing through unit per unit of time under standard air conditions, m^3/h or m^3/s .

3.4

Unit external static pressure

It refers to the static pressure difference of unit between inlet and outlet after overcoming unit resistance itself, at rated air flow rate, Pa.

3.5

Total static pressure

It refers to the sum of unit resistance itself and unit external static pressure, Pa.

3.6

Rated cooling capacity

It refers to the total heat extraction capacity of units under specified test operating condition, i. e. the sum of sensible heat extraction capacity and latent heat extraction capacity, kW or W.

3.7

Rated heating capacity

It refers to the total sensible heat capacity supplied by the unit under specified

test operating condition, kW or W.

3.8

Air leakage rate

The air leakage rate refers to the ratio between the air leakage amount and the rated air flow rate of the unit, which shall be represented in %.

3.9

Deformation rate

It refers to the ratio of casing deformation quantity and the longest length under test conditions, mm/m.

3.10

Face velocity uniformity

It refers to the percentage accounting for total measuring point quantity of those points that the absolute value of difference between air velocity and average air velocity not exceed 20% of average air velocity at any point quantity on unit section surface, %.

3.11

Standard air

It refers to the air state with temperature of _____ of 65%, atmospheric pressure of 101.3kPa and with density of 1.2kg/m³.

4 Classification and Mark

4.1 Classification

4.1.1 According to structural type

- a) Horizontal;
- b) Vertical;
- c) Suspended ;
- d) Others.

4.1.2 According to purpose and characteristics

- a) General units;
- b) Air purifying units
- c) Clean units;
- d) Special units: rooftop units, tobacco units, subway units and special units for data center.

4.1.3 According to specifications

The basic specifications of the unit may be represented with rated air flow rate, see Table 1.

Table 1 Basic Specifications

Specification code	2	3	4	5	6	7	8	10	15	20	25
Rated air flow rate/(m ³ /h)	2000	3000	4000	5000	6000	7000	8000	10000	15000	20000	25000
Specification code	30	40	50	60	80	100	120	140	160	200	
Rated air flow rate/(m ³ /h)	30000	40000	50000	60000	80000	100000	120000	140000	160000	200000	

4.2 Mark

4.2.1 The mark code shall comply with

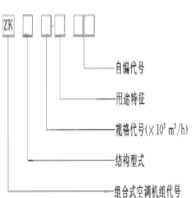

20000m³/h.

5 Materials

The thermal insulating and sound insulating materials adopted for unit casing shall be non-toxic, non-corrosive, free from peculiar smell and difficult of water absorption, and the exposed parts of these materials and the casing shall be non-flammable or flame retardant.

6 Requirements

6.1 Basic requirements

6.1.1 The units shall be manufactured according to those specified in this standard and the drawings and technical documents approved.

6.1.2 The structure of units shall meet the following requirements:

- a) The insulating layer and panel of unit casing shall be combined firmly and compactly. The heat resistance of panel insulation shall be no less than 0.74m² and the casing shall have cold bridge free measure;
- b) The inspection door of units shall be tight, flexible and safe;
- c) The outdoor unit casing shall have weather-proof and anti-frozen-protection;
- d) The water pipe shall be insulated and sealed when passing through unit casing;
- e) The casing of each functional section shall be free from permanent concave-convex deformation after transportation, startup, operation and stop;
- f) The unit shall be installed with drainage outlet, and the water discharge shall be smooth without spillage and leakage;
- g) The unit fan shall have flexible connection tube, and the fan shall be installed with vibration isolation device;
- h) The water spraying section shall be installed with inspection window, drip eliminator and water filtering device;
- i) The access door at filtration section shall be easy to take out the filter and shall have enough space for replacing;
- j) The airflow of crossing units section shall not generate short circuit;
- k) The measurement orifice and test instrument port may be remained if necessary, the voltage of safety lighting does not exceed 36V.

6.1.3 The fan, cooling and heating coil, filter, humidifier and air-air heat recovery device equipped in unit shall be accordance with the requirements of the relevant national standards.

6.1.4 The black metal surface of unit shall be with rust cleaning and anti-corrosion treatment.

6.2 Appearance

6.2.1 The unit external surface shall be free from obvious scuffing, rusty stain and pressed mark; its surface shall be smooth and clean with uniform spray coating and uniform color and free from flow mark, bubble and exfoliation.

6.2.2 The units shall be cleaned up and be clear of residues in the casing.

6.3 Performance

6.3.1 Startup and running

- a) The unit can normally start and run under rated voltage and rated frequency;
- b) The unit shall implement inspection and commissioning after installation in field.

6.3.2 Coil pressure performance

The unit shall be checked according to JB/T 9064 for pressure endurance and leak test ,and free from leakage.

- a) The pressure of air-pressure test shall be 1.2 times of design pressure and the pressure maintaining shall be at least 1 minute;
- b) The pressure of hydraulic test shall be 1.5 times of design pressure and the pressure maintaining shall be at least 3 minutes.

6.3.3 Air flow rate, unit external static pressure and input power

The measured value of air flow rate shall not be less than 95% of rated value under the test operating conditions specified in Table 4. The measured value of unit external static pressure shall not be less than 90% of rated value, and the measured value of input electric power shall not exceed 10% of rated value.

6.3.4 Air leakage rate

When the static pressure of units maintains at 700Pa in positive pressure section and -400Pa in negative pressure section, the air leakage rate shall be no more than 2%, but for the units used in purifying air-conditioning system, the static pressure shall maintain at 1000Pa and the air leakage rate shall be no larger than 1%.

6.3.5 Casing deformation rate

For the units which rated flow rate is larger than or equal to 30000m³/h, the deformation rate shall not exceed 4mm/m under the static pressure maintaining at 1000Pa.

6.3.6 Cooling capacity and heating capacity

The measured value of cooling capacity and heating capacity of units shall not be less than 95% of rated value under the test operating conditions specified in Table 4.

6.3.7 Air heat exchange efficiency of water spraying section

When the spraying pressure is less than or equal to 245kPa, the second air heat exchange efficiency shall not be less than 80%.

6.3.8 Condensation test

The unit surface shall be free from condensation dropping when running under test operating conditions specified in Table 4.

6.3.9 Discharging ability of condensation water

The discharge of condensation water shall be smooth and free from spillage when running under test operating conditions specified in Table 4.

6.3.10 Unit noise

The sound pressure level noise measured according to the method of 7.5.10 shall not be higher than those specified in Table 3.

Table 3 Unit Sound Pressure Level Noise Limit [dB(A)]

Rated air flow rate/(m ³ /h)	Total static pressure /Pa				
	350	500	750	1000	1500
2000~3000	60	63	66	69	72
5000	62	65	68	71	74
6000	63	66	69	72	75
10000	65	68	71	74	77
12000	66	69	72	75	78
20000	68	71	74	77	80
25000	69	72	75	78	81
30000	70	73	76	79	82
50000	72	75	78	81	84
80000	74	77	80	83	86
100000	75	78	81	84	87
160000	77	80	83	86	89
200000	78	81	84	87	90

Note: The value between air flow rate and total static pressure specified in table may be determined according to interpolation method.

6.3.11 Unit vibration

The amplitude of unit vibration shall not be more

6.3.12 Face velocity uniformity

It shall not be less than 80% according to the test method of 7.5.12.

6.3.13 Water flow rate and water resistance

The measured value of water resistance shall not exceed 10% of rated value according to the method specified in 7.5.13.

6.4 Safety performance

6.4.1 Insulation resistance

The insulation resistance value under cooling and heating states shall not be less , according to the test method 7.6.1.

7.1.2 The to-be-tested units shall be assembled and installed according to the requirements of product instruction, and any special treatment measure shall not be adopted except those specified in the test method.

7.2 Test conditions

Table 5 Permissible Deviation of Test Operation

Parameter		Permissible deviation of test operating condition	Permissible deviation of test operation
Inlet and outlet air	Dry bulb temperature /°C	±0.3	±0.5
	Wet bulb temperature /°C	±0.2	±0.3
Water supply state	Chilled water inlet temperature /°C	±0.1	±0.2
	Hot water inlet temperature /°C	±0.5	±0.5
	Water flow /%	±1	±2
	Water supply pressure (manometer pressure) /kPa	±5	±5
steam supply state	steam supply pressure /kPa	±1.7	±1.7
Air flow rate /%		±2	±2
Unit external static pressure /Pa		±5	±5
Voltage /%		±1	±2
Note: % in the table refers to the percentage of rated value.			

7. 2. 3 The meters used for test shall be in accordance with those specified in Table 6.

Table 6 Test Meter

Measuring parameter	Measuring meter	Measuring item	Meter accuracy
Temperature	Mercury thermometer, resistance thermometer and thermocouple thermometer	Air inlet/outlet dry and wet bulb temperature and heat-exchange equipment inlet/outlet temperature at cool and heat performance test	0.1°C
		Other temperatures	0.3°C
Pressure	Microbarograph (inclination, compensation or automatic sensing type)	Static air pressure and dynamic pressure	1 Pa
	U mercury gauge or other pressure gauge with identical accuracy	Water resistance and vapor pressure dropping	1.5hPa
	steam pressure gauge	steam supply pressure	2%
	Water pressure gauge	Water spraying pressure of water spraying section	2%
	Atmosphere pressure gauge	Atmospheric pressure	2hPa
Water quantity	Flowmeter, weight or capacity liquid quantity meter	Exchanger waterflow, de steam water flow and sprinkling chamber	1%

		waterflow	
Air flow rate	Standard nozzle (major diameter)	Unit air flow rate	1%
	Pitot	Unit air flow rate and air pressure	GB/T 1236-2000
Wind velocity	Anemoscope	Section velocity uniformity	0.25 m/s
Voltage	Voltmeter	Electrical parameter	Class 0.5
Current	Ammeter		
Power	Power meter		
Frequency	Frequency meter		
Noise	Sound level meter	Unit noise	0.5dB (A)
Vibration	Rideograph	Unit amplitude	5%
Time	Stopwatch	Condensate capacity	0.1s
Deformation	Long range dial gauge	Box deformation	±0.01mm
Note: % in the table refers to the percentage of measured value.			

7.3 Basic requirements

It shall be inspected with visual method.

7.4 Appearance

It shall be inspected with visual method.

7.5 Performance

7.5.1 Startup and running

- a) Turning on the testing units under rated voltage condition, after run five minutes steadily, cutting off electric power. Repeating the process in three times at least.
- b) Checking if there is abnormal phenomenon such as loose parts, noise and over heat of unit parts.

7.5.2 Coil pressure performance

It shall be tested under the test pressure specified in 6.3.2.

7.5.3 Air flow rate, unit external static pressure and input electric power

According to the method specified in Appendix A or Appendix B, set up the tests and convert the test results into the value under standard air condition.

7.5.4 Air leakage rate

The air leakage rate shall be measured according to the method specified in Appendix C.

7.5.5 Casing deformation rate

It shall be tested according to the method specified in Appendix D.

7.5.6 Cooling capacity and heating capacity

- a) Rated cooling capacity and heating capacity shall be tested according to the method of Appendix E under the test operating conditions specified in Table 4.
- b) The cooling capacity and heating capacity may also be worked out by directly quoting the heat transfer coefficient formula gained from air cooling and air heating coils test and may be verified according to the method specified in Appendix F.

7.5.7 Air heat exchange efficiency of water spraying section

It shall be tested according to the method specified in Appendix E.

7.5.8 Condensation test

After continuously running 4 hours under the cooling test operating conditions specified in Table 4, check the condensation situation of unit surface.

7.5.9 Discharging ability of condensation water

Fill the water in the condensate drain pan to drainage outlet, run continuously the unit 4 hours under the cooling test operating conditions specified in Table 4, check the drainage situation.

7.5.10 Unit noise

The unit noise shall be measured and calculated, under rated air flow rate and unit external static pressure conditions, according to the engineering method specified in 7.4 and 7.5 of GB/T 9068-1988.

7.5.11 Unit vibration

- a) The amplitude shall be measured at orthogonal three-dimensional direction of testing unit base with the meter specified in Table 6 under rated air flow rate and unit external static pressure conditions.
- b) Take the maximum value as the unit amplitude.

7.5.12 Section velocity uniformity

- a) The air velocity test points shall be set up uniformly at 200mm facing-airflow direction from coil or filter .
- b) The air velocity of each point shall be measured with anemoscope, and the percentage accounting for total points of those points that the difference between air velocity and average air velocity not exceeding 20% of average air velocity shall be counted.

7.5.13 Water flow rate and water resistance

The unit inlet/outlet water pressure drop (water resistance) shall be measured under

cooling operating condition specified in Table 4.

7.6 Safety performance

7.6.1 Insulation resistance

- a) The insulation resistance (cold state) of units among charged part and uncharged part shall be measured with 500V insulation resistance gauge under normal temperature and humidity conditions.
- b) The insulation resistance (hot state) of units among charged part and uncharged part shall be measured with insulation resistance gauge after 4 hours continuous operation under test operating conditions of discharging ability of condensation water specified in Table 4.

7.6.2 Electric strength

- a) Implying rated frequency and 1500V alternating voltage between charged part and uncharged metal part of units, the voltage shall not be larger than 50% of specified value at the beginning, then the voltage shall reach the total head rapidly and maintain this value for 1 minute;
- b) 1800V voltage and 1s may be replaced for large-lot production.

7.6.3 Leakage current

The unit leakage current between exposed metal part and wire shall be measured by implying 110% rated electric voltage after units continuously operate for 4 hours under test operating conditions of discharging ability of condensation water specified in Table 4.

7.6.4 Grounding resistance measurement

The resistance between unit casing and grounding terminal shall be measured with grounding resistance meter.

8 Inspection Rules

8.1 Inspection classification and inspection item

8.1.1 The inspection for the units is divided into EX-factory inspection, sampling inspection and prototype inspection .

8.1.2 The inspection items shall be carried out according to Table 7.

Table 7 Inspection Item

SN	Inspection item	Requirement	Test method	EX-Factory inspection		Prototype inspection		
				Inspection per set	Sampling inspection			
1	Basic provisions	5.1	7.3	Δ	Δ	Δ		
2	Appearance, marking and packing	6.2 9.1 9.2	7.4	Δ	Δ	Δ		
3	Performance requirement	Startup and running	6.3.1	7.5.1	Δ	Δ	Δ	
4		Coil pressure performance	6.3.2	7.5.2	Δ	Δ	Δ	
5		Air flow rate, unit external static pressure and input power	6.3.3	7.5.3	—	Δ	Δ	
6		Air leakage rate	6.3.4	7.5.4	—	Δ	Δ	
7		Deformation rate	6.3.5	7.5.5	—	Δ	Δ	
8		Cooling capacity and heating capacity	6.3.6	7.5.6	—	—	Δ	
9		Air heat exchange efficiency of water spraying section	6.3.7	7.5.7	—	—	Δ	
10		Condensation test	6.3.8	7.5.8	—	—	Δ	
11		Discharging ability of condensation water	6.3.9	7.5.9	—	—	Δ	
12		Unit noise	6.3.10	7.5.10	—	—	Δ	
13		Unit vibration	6.3.11	7.5.11	—	—	Δ	
14		Face velocity uniformity	6.3.12	7.5.12	—	—	Δ	
15		Water flow and water resistance	6.3.13	7.5.13	—	—	Δ	
16		Safety performance	Insulation resistance	6.4.1	7.6.1	Δ	Δ	Δ
17			Electric strength	6.4.2	7.6.2	Δ	Δ	Δ
18	Leakage current		6.4.3	7.6.3	Δ	Δ	Δ	
19	Grounding resistance		6.4.4	7.6.4	Δ	Δ	Δ	

Note: Item 9 shall be carried out for water spraying section. Item 1 and Item 2 are general items.

8.2 EX-Factory inspection

8.2.1 Each unit (each functional section) must be inspected by inspection department of manufacturer and accompanied by quality inspection qualification, before leaving factory.

8.2.2 The EX-Factory inspection of units shall be carried out per set according to items 1, 2, 3, 4, 16, 17, 18 and 19 specified in Table 7. Items 5, 6, and 7 shall be added for sampling inspection, one set shall be randomly inspected at least for each 20 sets, and one set shall be randomly inspected for those yearly output not reaching 20 sets.

8.3 Prototype inspection

8.3.1 The prototype inspection shall be carried out if having one of the following conditions:

- a) The new trial product is defined;
- b) The modification of structure, manufacture process and materials of defined products has influence on product performance;
- c) The production of resumption with the suspension has lasted for more than one year;
- d) The production field is changed;
- e) Setting prototype inspection once every three years in volume production;
- f) The national quality supervision institution puts forward the requirements for product supervision and spot checks.

8.3.2 Prototype inspection items should involve all in the table 7.

Table 8 sampling quantity

quantity/set	50	50
sampling quantity/set	1	2

8.3.3 Assessment rules

- a) A sample unit shall be judged unqualified if it fails any of the inspection items.
- b) In case one of the sample units is found unqualified, double sampling inspection shall be conducted; If there is still an unqualified unit in the second round of inspection, the batch of units shall be judged unqualified..

9. Marking, packaging, transportation and storage

9.1 Marking

9.1.1 Every unit should have production data plate fixed in the obvious part of the cabinet. The data plate should include the following contents;

- a) unit name model
- b) Main technical parameters (rated air flow rate unit external static pressure total static pressure, cooling capacity heating capacity rated voltage input power etc.)
- c) Overall dimension: length x width x height;
- d) Weight
- e) Number of manufacture
- f) Date of manufacture
- g) Manufacturer name

h) Adopted standard

9.1.2 Marks showing unit working status such as rotation direction, on/off signs, should be indicated and electrical circuit diagram should be attached.

9.2 Packaging

9.2.1 Each functional section of the unit should be packed according to respective requirements, and should be stable in the packing box.

9.2.2 Packing boxes should be strapped tightly.

9.2.3 There should be packing list, product qualification certificate, product installation instructions and other technical documents in the packing case.

9.2.4 Marks on the packing case should be not easy to fade, including contents as below:

- a) Product name model;
- b) Gross weight net weight;
- c) Overall dimension: length x width x height;
- d) ()th case, total () cases;
- e) Packing date;
- f) Arrival station (port) and receiver name;
- g) Deliver station (port) and sender name.

9.2.5 There should be storage and transportation signs such as moisture-proof, rainproof, anti-upside down, no rolling and careful handling on the packing case.

9.3 Transportation and storage

9.3.1 The unit should not be subjected to collision, extrusion, throw, rain or snow attack during transportation.

9.3.2 The unit should be stored in moisture-proof, rainproof and fireproof places, and there should be no corrosive gas around.

10 Basic contents of product catalogue and instruction

- a) Product name, model, operation principle, characteristics and application;
- b) Main technical parameters, including air flow rate, unit external static pressure, total static pressure, input power, cooling capacity and heating capacity and selection table or software under different operating conditions, water flow and water resistance;

- c) Structure dimension and electric wiring diagram;
- d) Adopted standard;
- e) Installation instruction and operation requirement;
- f) Maintenance attention.

Appendix A **(Appendix normative)**

Air Flow Rate, Air Pressure and electric Input Power Test Methods of Central-station Air Handling Units

Appendix A specifies the devices, conditions and methods of air flow rate, air pressure and electric input power tests of central-station air handling units.

A.1 Testing devices

A.1.1 The testing devices are composed of testing units, connecting pipe and duct measuring instrument.

A.1.2 The test devices shall be used according to one of the layouts of Figure A.1 and Figure A.2 specified in this Appendix.

A.1.3 The air flow nozzle listed as Figure A.1 for measuring air flow rate shall meet the following requirements.

- a) The nozzle throat velocity must be between 15m/s and 35m/s.
- b) The nozzle processing and installation shall be in accordance with those specified in Chapter 23 of GB/T 1236-2000.
- c) The nozzle size shall be in accordance with the requirements of long-radius nozzle of GB/T 2624.3-2006.
- d) The perforation rate of perforated plate shall be about 40%.

A.1.4 The laboratory device showed in Figure A.2 shall meet the following requirements.

- a) The Pitot tube shall be consistent to those specified in Chapter 27 of GB/T 1236-2000.
- b) The point quantity of measurement shall be consistent to those specified in Table A.1 and Figure A.3.
- c) The transition duct and air straightener shall be consistent to those specified in Chapter 30 of GB/T1236-2000.

A.1.5 The transfer duct of test device shall meet the following requirements:

- a) The single air-outlet units shall be installed with an outlet duct and the dimension shall be equal to the outlet size of testing units.
- b) The multiple air-outlet units shall be connected according to the method listed as Figure A.4.

A. 1. 6 All by-pass air dampers shall be shut off for multiple air-inlet units, and the air inlet valve flowing across each functional section of units shall only be opened and be in full open position.

A. 1. 7 The side access shall only be measured when the air flow rate of units is tested with air-air heat recovery device.

A. 2 Test conditions

A. 2. 1 The test shall be carried out according to the requirements in test operating conditions and testing instrument specified in Table 4 and Table 6 of 7.2 of this standard.

A. 2. 2 The testing units shall be the units composed of functional section and be equipped with fan, filtration and heat exchange section at least.

A. 3 Test methods

A. 3. 1 General requirements

a) At least five kinds of air flow rate, external static pressure and input electric power tests shall be carried out under rated voltage and rated frequency of fan. Each kind of test shall be measured three times and the test results shall convert to the average value.

b) Each air flow rate shall be measured according to clause A. 3. 2~A. 3. 7. The dynamic pressure, static pressure, input power, air flow rate, atmospheric pressure and outlet temperature of units shall be measured.

A. 3. 2 Static pressure measurement

a) Four static holes equally at measured section duct wall shall be connected into a static pressure loop, setting pressure measuring device of which one end shall be connected with this loop, and the other end shall be connected with environmental atmosphere.

b) The static hole diameter on the duct wall shall be 1mm~3mm, the hole side must be orthogonal without burr, and the internal diameter of pressure sampling pipe connection shall not be less than twice of static hole diameter.

A. 3. 3 Dynamic pressure measurement

a) When measuring the dynamic pressure with pitot tube, the straight pipe of pitot must be vertical to duct wall, the probe of pitot shall face the airflow direction and shall be parallel to duct axis. The measuring point position and point quantity shall be in accordance with those specified in A. 1. 4b).

b) After measuring the dynamic pressure of each point with pitot on the same section, the average dynamic pressure shall be calculated according to the Formula (A.1).

$$P_d = \frac{\sqrt{P_{d1}} + \sqrt{P_{d2}} + \dots + \sqrt{P_{dn}}}{n} \quad (A.1)$$

Where:

P_d — the dynamic pressure, Pa;

$P_{d1}, P_{d2}, \dots, P_{dn}$ — the dynamic pressures of n measuring points ;

N — the measuring point number

c) When measuring the air flow rate with air flow nozzle, the average dynamic pressure may be calculated according to the Formula (A.2).

$$P_d = \frac{L^2}{2 \cdot 3600 A_2^2} \quad (A.2)$$

Where:

ρ_2 — the outlet air density of units, kg/m^3 ;

$$\frac{P_t - B}{287T}$$

L — the unit air flow rate, m^3/h ;

A_2 — the sectional area of measured duct, m^2

B — the atmospheric pressure, Pa;

P_t — the total pressure of unit outlet air, Pa, $P_t = P_d + P_s$

P_s — the unit outlet static pressure, Pa;

T — the unit outlet thermodynamic temperature, K, $T = 273.15^\circ\text{C}$;

t_2 — the unit outlet temperature, $^\circ\text{C}$

A.3.4 Air flow rate measurement

a) When measuring the air flow rate with pitot, the air flow rate of units shall be calculated according to Formula (A.3).

$$L = 3600 A_2 \sqrt{\frac{2P_s}{\rho_2}} \quad (A.3)$$

b) When measuring the air flow rate with airflow nozzle device, the air flow rate of each nozzle shall be calculated according to Formula (A.4).

$$L_0 = 3600 AC \sqrt{\frac{2 P_s}{\rho_2}} \quad (A.4)$$

Where:

L the air flow rate flowing across each nozzle, m^3/h ;

C the discharge coefficient of flow nozzle, see Table A.2;

A the nozzle area, m^2 ;

the pressure difference before and after nozzle, Pa;

When measuring with multiple nozzles, the unit air flow rate shall be equal to

the sum of air flow rate with all nozzle measurement.

A. 3.5 Temperature measurement

The unit outlet temperature shall be measured by inserting thermometer into testing duct.

A. 3.6 Atmospheric pressure measurement

It shall be measured with atmosphere pressure gauge near units, at the beginning and end of the test shall be needed, and the average shall be adopted.

A. 3.7 While measuring the air flow rate, such parameters as input electric power or current and voltage shall be measured directly.

A. 4 Data summary

A. 4.1 The test results shall be converted into the air flow rate (L_0) and static pressure (P_0) under standard air.

$$\text{Air flow rate } L_0 = \frac{L}{1.2} ;$$

$$\text{Static pressure } P_0 = \frac{1.2P_s}{2}$$

A. 4.2 The testing unit shall provide the performance diagram or curve of unit with external static pressure and input power and air flow rate.

Table A.1 Measuring Point Position with Pitot tube Measurement

SN	Distance to internal wall	SN	Distance to internal wall
1	0.021D±0.0006D	5	0.665D±0.005D
2	0.117D±0.0035D	6	0.816D±0.005D
3	0.184D±0.005D	7	0.883D±0.0035D
4	0.345D±0.005D	8	0.979D±0.0006D

Table A.2 Discharge Coefficient of Flow Nozzle C

Re	14720	15491	16314	17195	18317	19148
C	0.950	0.951	0.952	0.953	0.954	0.955
Re	20234	21402	22661	24021	25492	27086
C	0.956	0.957	0.958	0.959	0.960	0.961
Re	28817	30701	32758	35006	37472	40184
C	0.962	0.963	0.964	0.965	0.966	0.967
Re	43174	46482	50153	54242	58815	63948
C	0.968	0.969	0.970	0.971	0.972	0.973
Re	69736	76295	83765	92320	102180	113620
C	0.974	0.975	0.976	0.977	0.978	0.979
Re	126992	142743	161500	184032	211428	245182
C	0.980	0.981	0.982	0.983	0.984	0.985

Re	287409	341172	411057	504164	631966	813986
C	0.986	0.987	0.988	0.989	0.990	0.991
Re	1085643	1516727	2260760	3712194		
C	0.992	0.993	0.994	0.995		

Note: Re is the Reynolds number, $Re = \frac{VD}{\nu}$ where, V is the air velocity of nozzle throat (m/s), D is the diameter of nozzle

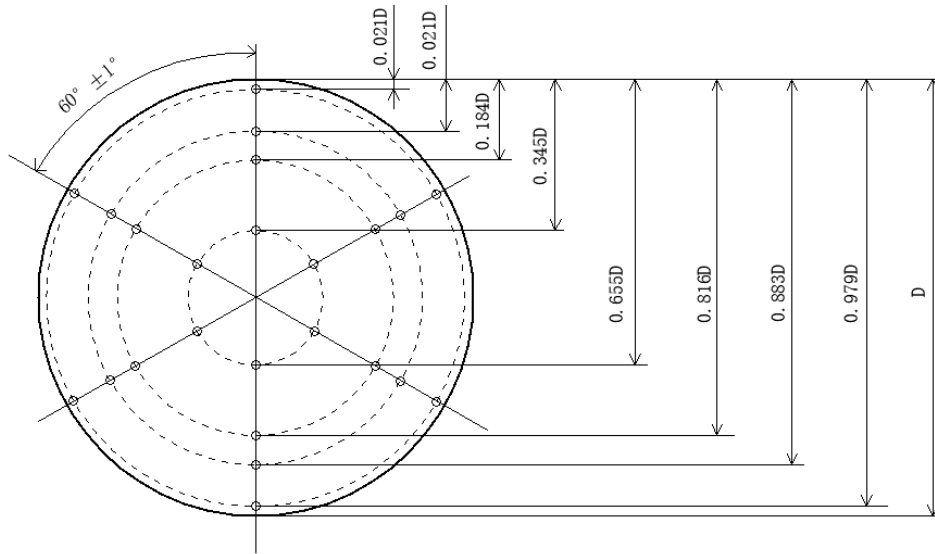

○ Measuring point

Figure A.3 Position of Measuring Point in Standardized duct

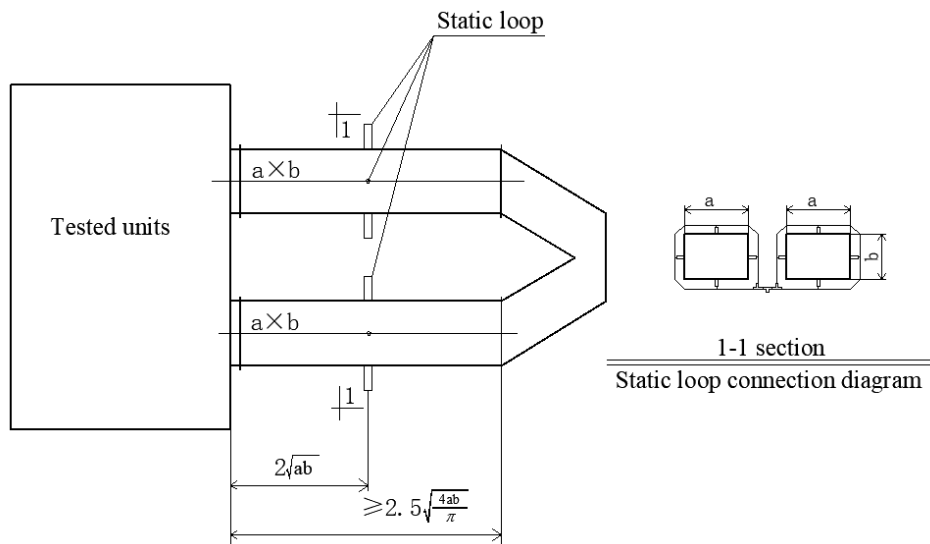

Note: When multiple outlets are composed into a large air outlet with the same flange, the units may be considered according to single air outlet units.

Figure A.4 Diagram of Unit Measuring Section with Multiple Air Outlets

Appendix B
(Appendix normative)
Field Test Methods for Air Flow Rate, Air Pressure and Input Power of
Central-station Air Handling Units

This Appendix specifies test conditions and methods of air flow rate, air pressure and input power of central-station air handling unit installed in the field.

B.1. General requirement of field test

B.1.1 No air leakage is allowed between the testing unit and the duct which for measuring the air flow rate and pressure.

B.1.2 The testing unit shall be measured under the rated air flow rate which fluctuation shall be within 10%.

B.1.3 The test operating condition of the unit may be regulated by the system air damper without disturbing the air flow in the measured section.

B.1.4 The test shall be carried out according to the test operating conditions and test instrument accuracy specified in 7.2 of this standard.

B.2 Test methods

B.2.1 Measurement of air flow rate

B.2.1.1 The measured section shall be selected on the straight duct sections at the inlet and outlet of the unit, with a distance more than two times of the equivalent diameter of duct away from the upstream local resistance part.

B.2.1.2 See Table B.1 for the number of the measuring points in the rectangular section, and the specific requirements are listed as following:

- a) When the length-width ratio of the rectangular section is less than 1.5, at least 25 points shall be arranged in the section, see Figure B.1. For the section in length above 2m, at least 30 points shall be arranged (with 6 ordinates, and 5 points on every line).
- b) When the length-width ratio of the rectangular section is no less than 1.5, at least 30 points shall be arranged in the section (with 6 ordinates and 5 points on every line).
- c) For the section with its long length under 1.2m, it may be divided into several small interfaces in equal areas, and the side length of every small interface shall be 200 mm~250mm.

B. 2. 1. 3 The measuring points in circular cross-section may be arranged in accordance with Figure B. 2 and Table B. 2.

B. 2. 1. 4 Measuring method

- a) The speed at every point shall be measured. Generally, the speed may be measured by adopting with pitot and microbarograph, however, the other instruments such as thermoelectric anemograph is recommended to be adopted when the dynamic pressure value is less than 10 Pa.
- b) The average speed on the section shall be calculated according to Formula (B. 1)

$$V = \frac{V_1 + V_2 + \dots + V_n}{n} \quad (\text{B.1})$$

Where:

- V —the average speed, m/s;
V₁, V₂.....V_n—the speed at each measuring point, m/s;
N —the number of measuring points.

- b) The measurement shall be repeated for at least three times and the average value shall be taken.
- d) The air flow rate shall be derived from the air speed and the area of the section.

B. 2. 2 Measurement of unit inlet/outlet static pressure

B. 2. 2. 1 The unit inlet and outlet static pressure shall be measured directly near to the connecting duct of unit.

B. 2. 2. 2 The pressure sampling hole shall be adapted to measure static pressure, the sampling hole shall be orthogonal, the internal surface must be lubricous. If the section is rectangular section, the sampling hole shall be in the center of the side wall.

B. 2. 2. 3 The pitot and manometer shall be adapted to measure the static pressure on the section. The measurement shall be repeated for three times and the average value shall be taken.

B. 2. 3 Unit external static pressure

The unit external static pressure (P_s) shall be calculated according to Formula (B. 2)

$$P_s = P_{s2} - P_{s1} \quad (\text{B. 2})$$

Where:

- P_{s2}, P_{s1} the inlet/outlet static pressure of the unit, Pa

B. 2. 4 Power measurement

The input power, electric current or voltage of the units shall be measured directly with dynamometer or ampere-voltage meter.

B. 2. 5 The test results shall be reduced to the value under standard air.

Table B.1 Measuring Point Layout on Rectangular Section

Number of Ordinate	Number of Points on Each Ordinate	x_1/L or y_1/H
5	1	0.074
	2	0.288
	3	0.500
	4	0.712
	5	0.926
	1	0.061
	2	0.235
	3	0.437
	4	0.563
	5	0.765
	6	0.939
7	1	0.053
	2	0.203
	3	0.366
	4	0.500
	5	0.634
	6	0.797
	7	0.947

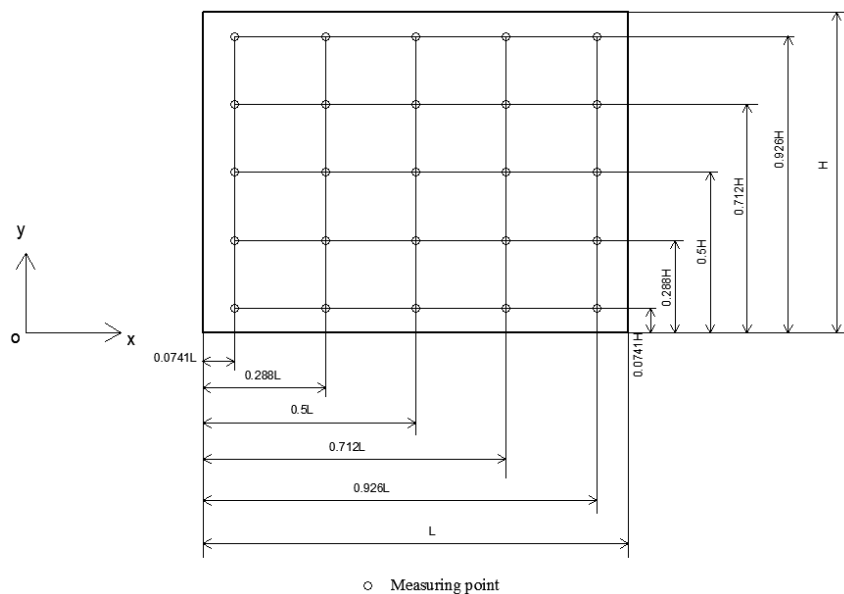

Figure B.1 Layout of 25 Points on Rectangular Vent pipe

Table B.2 Measuring Point Layout on Circular Section

Dia. of Air Condit Number of Cirque	≤200	200~400	400~700	≥700
	3	4	5	5~6
Serial Number of Points	Distance from measuring point to pipe wall (times of r)			
1	0.1	0.1	0.05	0.05
2	0.3	0.2	0.20	0.15
3	0.6	0.4	0.30	0.25
4	1.4	0.35	0.50	0.35
5	1.7	0.65	0.70	0.50
6	1.9	0.80	1.30	0.70
7		0.90	1.50	1.30
8		0.95	1.70	1.50
9			1.80	1.65
10			1.90	1.75
11				1.85
12				1.95

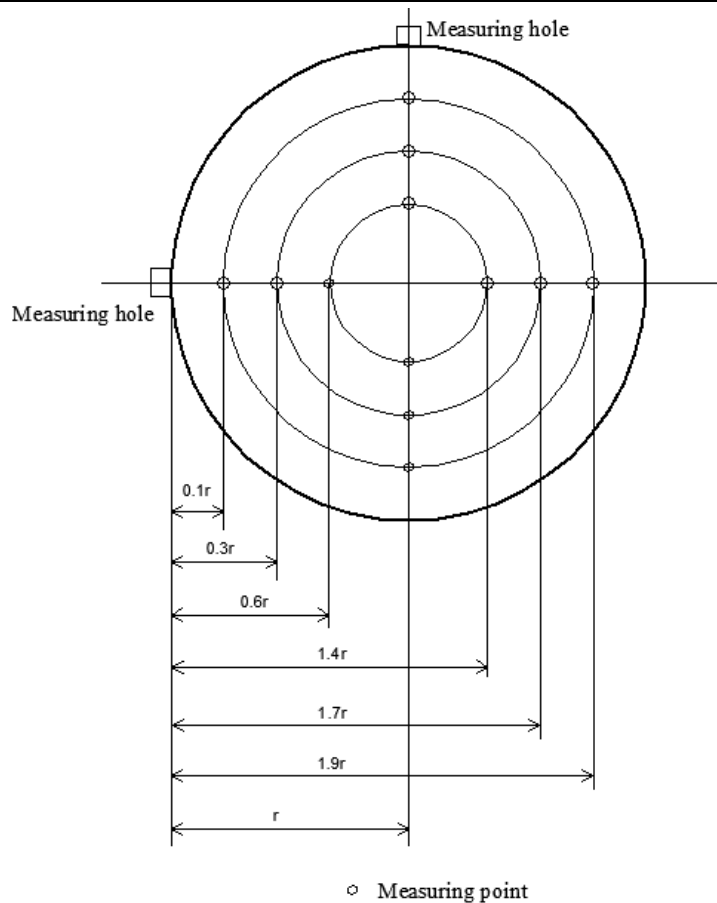

Figure B.2 Measuring Point Layout of Circular Vent Pipe with three Circular Rings

Appendix C (Appendix normative)

Test Method for Air Leakage Rate of Central-station Air Handling Units

This Appendix specifies the test method for air leakage rate.

C.1 Installation of tested unit and its test shall be arranged according to Figure C.1

- a) For the units with multiple air inlets, all the air inlets shall be assembled into one measuring duct;
- b) The part from the air inlet of the testing unit to the measured section shall be airtight without leakage.
- c) The air flow velocity in the measured vent duct shall be no less than 6.5m/s when adopting the testing layout as shown in Figure C.1.

C.2 Test conditions

The test shall be carried out according to the test conditions specified in 7.2 of this standard.

- a) The units only working under negative pressure section shall be tested according to 400Pa negative pressure and Figure C.1b).
- b) The units only working under positive pressure section shall be tested according to 700Pa positive pressure and Figure C.1a).
- c) The units working under both positive pressure and negative pressure may be tested in accordance with the positive pressure, or positive and negative pressure respectively.
- d) The air purifying units shall be tested according to 1000Pa positive pressure and Figure C.1a).

C.3 Test methods

- a) All outlet valves of the unit shall be shut for positive pressure unit and do test as shown in Figure C.1a). All inlet valves of the unit shall be shut for negative pressure unit and do test as shown in in Figure C.1b). All sections of the unit should be sealed.
- b) The throttling device shall be used to make the units reaching the required static pressure value;
- c) The air flow rate measured by flow nozzle or pitot on the measured duct shall be the leakage rate of units, and it shall be converted into the air flow rate under standard air condition. When the dynamic pressure is less than 10Pa, the thermoelectric anemometer may be adopted for measuring the air flow rate;
- d) The air leakage rate of units shall be calculated according to Formula (C.1).

$$e = \frac{L_s}{L} \cdot 100 \quad (C.1)$$

Where:

e —the air leakage rate of the units, %

L_s —the air leakage of the units under the standard air condition, m^3/h ;

L —the rated air flow rate of the units, m^3/h .

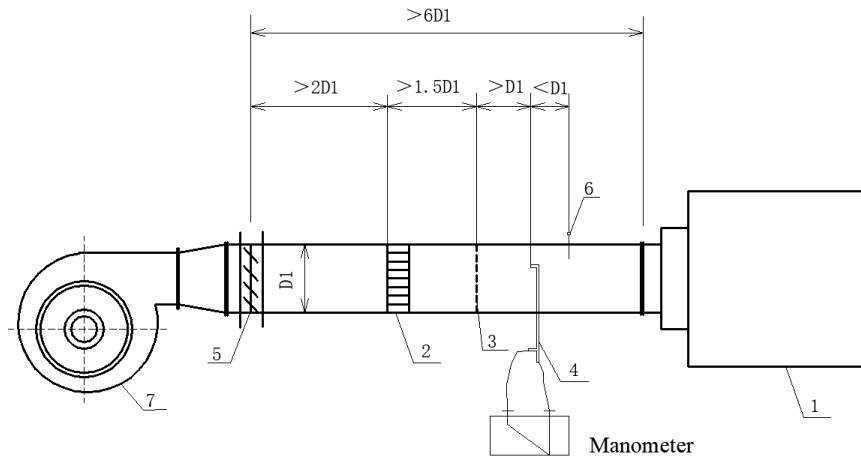

a) Positive pressure section

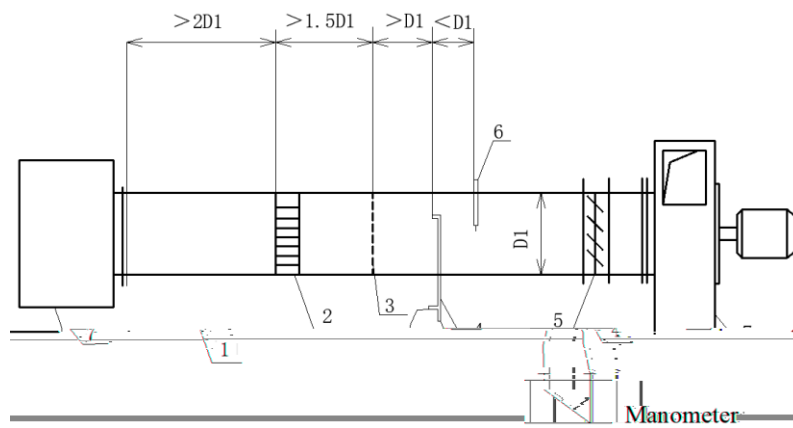

b) Negative pressure section

- 1—Test units
- 2—Straightener
- 3—Current equalizer
- 4—Instrument of flow rate measurement (Pitot, nozzle or air flow meter);
- 5—Control valve
- 6—Thermometer
- 7—Make-up fan

Figure C.1 Layout Diagram of Air Leakage Test

Appendix D
(Appendix normative)

Test Method for Deformation Rate of Central-station Air Handling Units

This Appendix specifies the test conditions and test methods for the deformation rate of central-station air handling units.

D.1 The deformation rate test of the tested central-station air handling units shall be arranged in accordance with those specified in Figure D.1D.1.1 Installation of testing units

For the testing unit, its base shall be fixed firmly in horizontal; all of its air inlet or outlet shall be covered with closure plate and sealing materials so that no air leakage may occur; the test holes shall be obligated in the center of closure plate to install intake pipe connector for pressure loading; metering orifice of 1 mm~3 mm in diameter shall be obligated in the top right corner of the closure plate to install static pressure measurement connector in the units.

D.1.2 The test equipment consists of the pressure loading device, pressure test equipment and dial indicator measuring device in wide range.

D.2 Test methods

- a) Visual method may be adopted in the selecting of measuring point in the section of maximum deformation;
- b) For the fixed dial indicator bracket, the dial indicator pointer shall be directed to the test point and be adjusted to touch the units with its point tip. And the current dial indicator reading value shall be recorded as h_1 in zero-pressure conditions;
- c) Pressure loading device shall be started to load pressure in the units, and the static pressure test equipment shall be adopted to measure the static pressure value in the units. When the static pressure reaches the specified value, the dial indicator value shall be read as h_2 after 1 minute;
- d) The unit deformation is $|h_2 - h_1|$; the maximum value shall be taken as the amount of deformation for the air-handling units in three repeating times.
- e) The deformation rate of the casing is the result of the maximum deformation volume divided by the longest side of this section and shall not be larger than 4 mm/m.

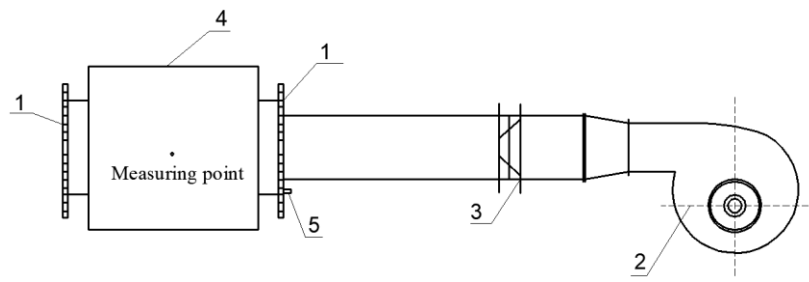

a) Positive pressure device

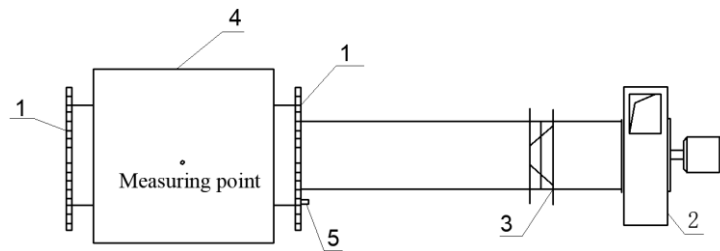

b) Negative pressure device

- 1—Closure plate
- 2—Pressure loading device
- 3—Control valve
- 4—Units in test;
- 5—Static pressure testing interface.

Figure D.1 Pressure-tight and Deformation Test Device of Units

Appendix E
(Appendix normative)
Test Method for Cooling Capacity and Heating Capacity of Central-station
Air Handling Units

This Appendix specifies the test equipment, method and calculation of cooling capacity and heating capacity for central-station air handling units as well as the test method for determining water spraying section performance.

E.1 Testing Equipment

Test equipment consists of air system and water system (or steam system). Test equipment in Table E.1 or Table E.2 of this Appendix shall be adopted to carry out experiments.

E.1.1 air system

- a) The pretreatment section shall include the functions with heating, humidification, refrigeration, dehumidification, air mixture, flow equalization and air delivery.
- b) The measuring section must be sealed and heat insulated and the air leakage rate shall be no more than 1% of the rated air flow rate. And the heat leakage volume shall be no more than 2% of the air-side heat exchange capacity.
- c) Before measuring section of air flow rate and air temperature as well as humidity, air mixer and air equalizer shall be installed. The air mixer shall comply with provisions specified in Appendix B in JG/T 21 1999 the air equalizer may be adopted with metal mesh or perforated plate;
- d) Measuring devices of air flow rate, dry and wet-bulb temperature and air-pressure in air way system shall be provided;
- e) Air flow rate nozzle may be adopted in measuring air flow rate, refer to Appendix A.1.3 of this standard;
- f) Sampling devices specified in JG/T 21-1999 shall be adopted to measure the dry-and-wet-bulb temperature of air inlet and outlet of the testing units.
- g) The distance of the outlet static pressure measuring section to the outlet shall be twice the equivalent diameter of air outlet. The distance of the inlet static pressure measuring section to the inlet shall be half the equivalent diameter of air inlet. See Appendix A of this standard about the practice of static opening and static pressure loops.
- h) The connection of multi-air outlet unit shall refer to the requirements in Appendix A of this standard;
- i) The multi-inlet air unit only opens the main air inlet, and the rest shall all be closed so that no air or heat leaks.

E.1.2 Water loop system

- a) Pretreatment section shall be included with water heating, refrigeration and transportation as well as the control functions of water temperature and water

volume;

b) The measurement of water volume, water temperature and water pressure drop shall be allowed to carry out in water loop system. Measuring devices shall be satisfied with those specified in JG/T 21-1999.

E. 1.3 Steam system

a) Pretreatment section shall be included with steam generating device, steam supply-distribution device (such as vapor-water separator and steam trap) and regulation and control device of vapor parameter.

b) Measurement of steam pressure, temperature, condensation water volume and temperature of the condensation water shall be allowed to carry out in steam system. And the measuring devices shall be in accordance with those specified in JG/T 21-1999.

E. 2 Test Conditions

The test shall be carried out in accordance with the operating conditions and test meter requirements in 7.2 of this standard.

E. 3 Test Method

E. 3.1 Test equipment shall be adjusted so that air flow rate, air pressure, air and water (or steam) parameters of the testing unit shall satisfy the requirements on operating conditions. Measurement is carried out at least 15 minutes after it is steady. The measuring result shall be recorded in 5 minutes interval and the average value of each reading shall be regarded as the measured value of the test for half-hour of continuous measurement.

E. 3.2 Two methods shall be adopted to calculate heat exchange capacity. One is to calculate the heat exchange capacity according to the air-side measured value; another is to calculate according to the water-side (or steam-side) measured value. Thermal balance deviation between methods shall not exceed value of both results shall be regarded as the heat exchange capacity of the units.

E. 4 Data Recording of Test

The data needs recording are as follows.

The recording content of serial number and cooling (heating) capacity

1 Date

2 Testers

3 Manufacturers

4 Units model

5 Name of cold and hot medium

6 Model, specification, size and structural diagram of coil

7 Model, specification and layout diagram of coil section

- 8 Model, specification and layout diagram of fan section
- 9 Model, specification and layout diagram of other functional sections taking involved in the test
- 10 Atmospheric pressures
- 11 Dry-bulb temperature and wet-bulb temperature of air entering the testing units
- 12 Dry-bulb temperature and wet-bulb temperature of air exiting from the testing units
- 13 Dry bulb temperature and total pressure of air that enters into the air flow nozzle
- 14 Front and rear static pressure difference of nozzle or the dynamic pressure in the nozzle exit
- 15 Quantity and diameter of the applied nozzle
- 16 Static pressures in the entrance of the testing units
- 17 Static pressures in the exit of the testing units
- 18 Air duct size in the entrance and exit of the testing units
- 19 water inlet temperature of the testing units
- 20 Outlet water temperatures of the testing units
- 21 Supply temperature of chilled water
- 22 Water pressure drops of testing units
- 23 Water flow rate of the testing units
- 24 Inlet steam pressure and temperature of the testing units
- 25 Temperature when the condensation water of testing units exits
- 26 Condensation water volumes of the testing units
- 27 Steam pressure drops of the testing units
- 28 Input power, voltage, current and frequency of the tested units

E.5 Calculation of Testing Result

E.5.1 Calculation of air flow rate

a) Formula (E.1) is adopted to calculate the air flow rate going through single nozzle.

$$L_1 = C_1 A_1 \sqrt{\frac{2 P_1}{\rho_1}} \quad (\text{E. 1})$$

Where:

- L_1 the air flow rate of nozzle, m^3/s ;
- C_1 the nozzle-discharge coefficient, see Appendix A;
- P_1 the front and rear static pressure difference or dynamic pressure in the throat part of the nozzle;
- A_1 the nozzle area, m^2 ;
- ρ_1 the air density in nozzle, kg/m^3 , the calculation formula, see Formula (E.2).

$$\rho_1 = \frac{P_1(1 - d_1)}{461T_1(0.622 - d_1)} \quad (\text{E. 2})$$

Where:

P_1 the absolute pressure of air in nozzle, Pa; $P_1 = P_t + B$; B refers to atmospheric pressure; P_t refers to total pressure;

T_1 the aerothermodynamics temperature in nozzle, K;

d_1 the air moisture in nozzle, kg/kg_{dry air}

b) When multiple nozzles are adopted, the total air flow rate (L) is equal to the sum of air flow rate through each nozzle.

E. 5. 2 Air-side heat exchange capacity is calculated through the Formula (E. 3) under cooling condition.

$$Q_a = \frac{L_1}{(1 - d_1)} [(I_1 - I_2) C_{pw} t_{2s} - d] \quad (E. 3)$$

Where:

Q_a the air-side heat exchange capacity, kW;

I_1 the enthalpy value of inlet air of the testing units, kJ/kg_{dry air};

I_2 The enthalpy value of outlet air of testing units, kJ/kg_{dry air};

C_{pw} Specific heat at constant pressure of water, kJ/(kg•K), may be adopted with 4.18 kJ/(kg•K);

d the inlet and outlet air moisture difference of the testing units kg/(kg•K)

t_{2s} the outlet air wet-bulb temperature of the testing units

E. 5. 3 Water-side heat exchange capacity under cooling condition shall be calculated according to the Formula (E. 4).

$$Q_w = WC_{pw}(t_{w2} - t_{w1}) - N \quad (E. 4)$$

Where:

Q_w the water-side heat exchange capacity, kW;

W the water mass flow rate or condensation water mass flow rate of steam, kg/s;

t_{w1} the w

t_{w2} the w

N the input power of testing units, kW.

E. 5. 4 Air-side heat exchange capacity under heating condition shall be calculated according to the Formula (E. 5).

$$Q_a = \frac{L_1}{(1 - d_1)} C_{pa}(t_2 - t_1) \quad (E. 5)$$

Where:

t_1 the inlet air temperature of the testing unit

t_2 the outlet air temperature of the testing unit

C_{pa} the specific heat at constant pressure of air, kJ/

E. 5. 5 Water-side heat exchange capacity is calculated through the Formula (E. 6) when it is heated.

$$Q_w = WC_{pw}(t_{w1} - t_{w2}) N \quad (E. 6)$$

E. 5. 6 Steam-side heat exchange capacity is calculated through the formulae (E. 7) when it is heated.

$$Q_z = W(I_{v1} - I_{v2}) \quad (E. 7)$$

Where:

Q_z the steam-side heat exchange capacity, kW;

I_{v1} the enthalpy value of inlet steam, kJ/kg;

I_{v2} the enthalpy value of outlet steam, kJ/kg;

E. 5. 7 Deviation between air-side and medium-side heat exchange capacity adopted in test shall be limited within

E. 5. 8 Heat exchange capacity of units shall be calculated through the following Formula (E. 8).

$$Q = \frac{Q_a + Q_j}{2} \quad (E. 8)$$

Where:

Q the heat exchange capacity of testing units, kW;

Q_j the medium-side heat exchange capacity, kW; It equals to Q_w , when refrigerated or heated with water, and to Q_z when heated with steam.

E. 6 Performance test method of spray section

E. 6. 1 Test equipment

- a) Water side testing system may be arranged according to Table E. 3;
- b) The pretreatment section and measuring device in air system and water system are the same with those specified in E.1 of this Appendix. However the atmospheric sampling tube is generally arranged in front in the air split slab and behind the breakwater in water spraying section.

E. 6. 2 Test method and result calculation

E. 6. 2. 1 The test shall be carried out in accordance with the requirements on the operating conditions and test meter specified in 7. 2 of this standard.

E. 6. 2. 2 Test equipment shall be adjusted so that air and water could meet the

requirements demanded by the operating condition. And the measurement shall not begin until after at least 15 minutes when the test equipment is settled. The measuring result shall be read every 5 minutes and the average value of each reading shall be regarded as the measured value of the test for 30 minutes of continuous measurement.

E. 6.3 Calculation of cooling capacity

a) Air side cooling capacity shall be calculated through the following formulae (E. 9).

$$Q_a = \frac{L_1 - l_1}{(1 - d_1)} [(I_1 - I_2) C_{pw} t_{2s} - d] \quad (\text{E. 9})$$

Where:

Q_a the air-side cooling capacity of water spraying section, kW;

l_1, l_2 the enthalpy value of inlet and outlet air of the water spraying section, kJ/kg dry air.

b) Cooling capacity of water spraying side shall be calculated according to Formula (E. 10), or Formula (E. 11) and (E. 12)

$$Q_w = W_2 C_{pw} (t_{w2} - t_L) \quad (\text{E. 10})$$

$$Q_w = (W_1 t_{w1} - W_2 t_{w2}) C_{pw} \quad (\text{E. 11})$$

$$W_2 = W_1 \frac{L_1 - l_1}{1 - d_1} (d_1 - d_2) \quad (\text{E. 12})$$

Where:

Q_w the water-side heat exchange capacity of water spraying section, kW;

W_2 the backwater volume of water spraying section, kg/s;

t_{w2} the outlet water temperature of

t_L the s

W_1 the supply water flow rate of water spraying section, kg/s;

t_{w1} the inlet water temperature of water spraying section

d_1, d_2 the inlet and outlet air moisture of the water spraying section, kJ/kg_{dry air}.

Note: see Table E.3 for the relationship between water temperature and water flowrate of water spraying section. 3.

c) Cooling capacity deviation of both sides shall be limited within

d) Cooling capacity of water spraying section shall be adopted with the average value of air-side and water-side capacity (see E. 13).

$$Q = \frac{Q_a + Q_w}{2} \quad (\text{E. 13})$$

Where:

Q the cooling capacity of water spraying section, kW.

E. 6. 4 Humidifying capacity of water spraying section shall be calculated through Formula (E. 14)

$$W_a = \frac{L_1}{1} \frac{1}{d_1} (d_2 - d_1) \quad (\text{E. 14})$$

Where:

W_a the humidification capacity of water spraying section, kg/h.

E. 6. 5 Water-air ratio shall be calculated through the Formula (E. 15).

$$\frac{W_1(1 - d_1)}{L_1} \quad (\text{E. 15})$$

Where:

the water-air ratio in water spraying section

E. 6. 6 Water spraying pressure

Water spraying pressure shall be measured at the same time while the cooling capacity (or humidification capacity) and water-air ratio are measured. Water spraying pressure shall be measured with pressure gauge in the water supply pipe inlet of the water spraying section.

E. 6. 7 See Formula (E. 16) for the calculation of the second heat exchange efficiency of air.

$$\eta = \frac{t_2 - t_{s2}}{t_1 - t_{s1}} \quad (\text{E. 16})$$

Where:

η the heat exchange efficiency of air;

t_1, t_2 the dry bulb temperature of inlet and outlet air of water spraying

t_{s1}, t_{s2} the wet bulb temperature of inlet and outlet air of water spraying

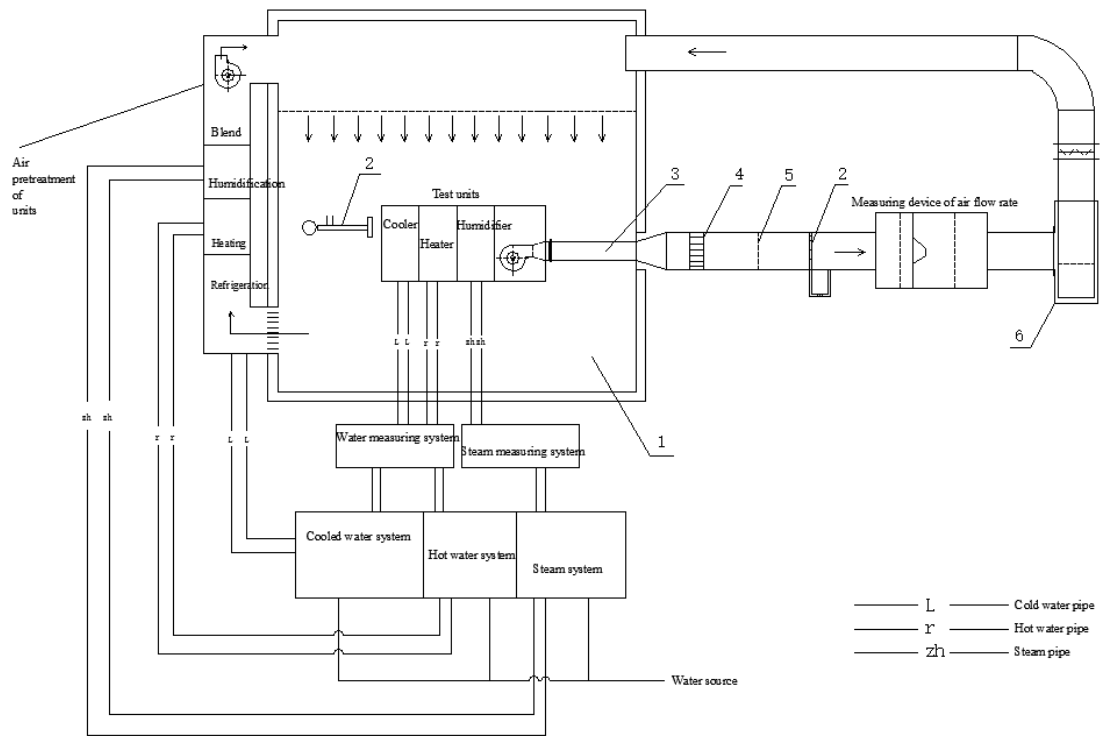

- 1—Test environment compartment;
- 2—Sampling device;
- 3—Static pressure loops;
- 4—Air mixerr;
- 5—Air equalizer;
- 6—Make-up fan

Figure E.1 Test Equipment of Room Air Enthalpy Potential Method

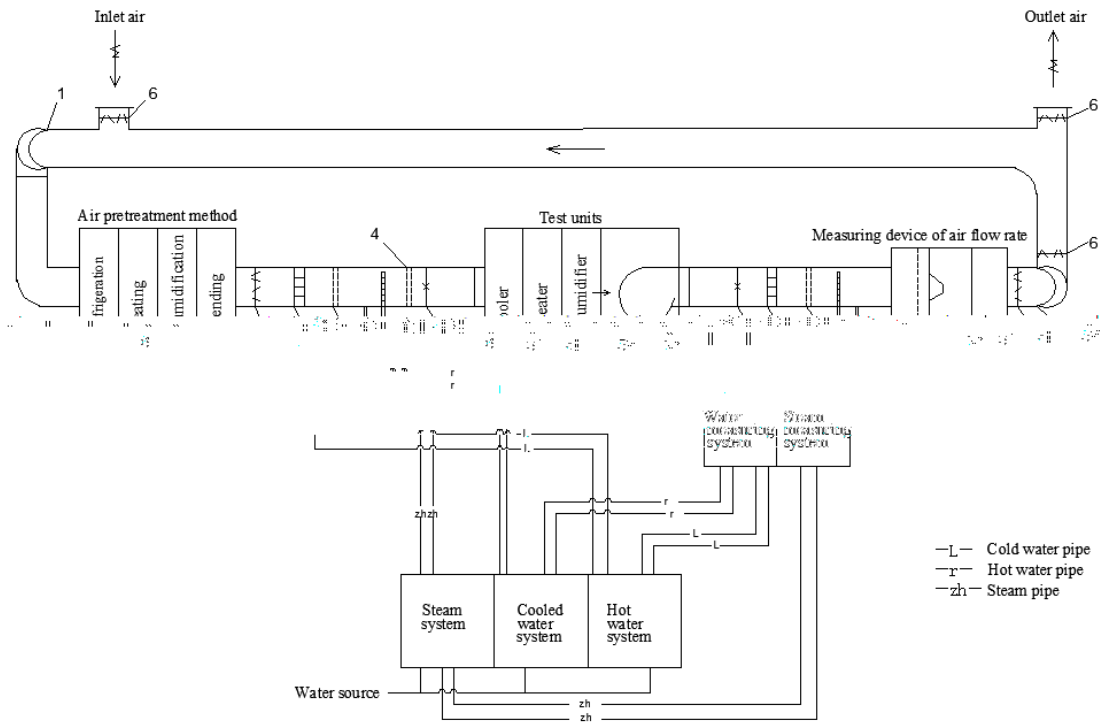

- 1—System fan;

- 2—Static pressure loops;
- 3—Blender;
- 4—Current equalizer;
- 5—Sampling device;
- 6—Air valve.

Figure E.2 Test Equipment of Duct Loop Air Enthalpy Potential Method

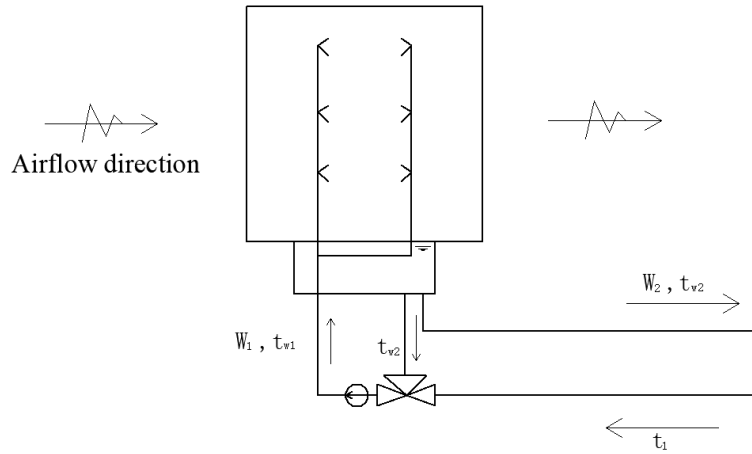

Figure E.3 Diagrams of Water Temperature and Flow Rate of Water Spraying Section

F.2.4 When the steam supply pressure is in any state of 14kPa~700kPa, the fluctuation shall not exceed 3kPa.

F.2.5 The water spraying pressure fluctuation of water spraying section shall not exceed 5kPa.

F.3 Test equipment

It shall be in accordance with those specified in 7.2 of this standard.

F.4 Test methods

After inlet air parameter and medium parameter of testing units reaching the stable test operating conditions state and lasting 15 minutes, the heat exchange capacity of medium side shall be measured. Reading figure per 10 minutes, continuously measuring 30 minutes, and the mean value of readings shall be taken as the measured value.

The parameters both in air and media side shall be measured simultaneously, and the air flow rate and static pressure may be read every 10 minutes.

F.4.1 Measurement of air flow rate and static pressure

The measurement of air flow rate and static pressure shall be carried out according to the method of Appendix B of this standard.

F.4.2 Measurement of inlet air temperature and humidity state

a) When the measured section is coil or water spraying section, the measuring points shall be set up on the upstream section distancing 200mm from coil or water spray. This section may be equally divided into 6~9 homolographic small rectangle, the dry bulb temperature and wet bulb temperature of air shall be measured at each small rectangle center, and the mean value shall be taken as the air inlet value.

b) When the measured section is on the inlet air duct of tested units, the method of atmospheric sampling or average spotting on section may be adopted to measure the air dry bulb temperature and wet bulb temperature. See Appendix B for the method of average spotting on section.

c) When the test adopt outdoor air to intake air, the air dry bulb temperature and wet bulb temperature may only be measured with single point near air inlet.

F.4.3 Water side measurement

a) The inlet/outlet water temperature and water flow rate of cool and heat coil shall be measured.

b) The inlet water pressure in the front of nozzle, return water flow, chilled water supply temperature and return water temperature of water spraying section shall be measured.

c) The inlet steam pressure, temperature, condensate capacity and condensate temperature of vapor heater shall be measured.

F.5 Test result calculation

F.5.1 The water side heat exchange capacity of cooling coil shall be calculated according to the Formula (F.1):

$$Q_w = WC_{pw}(t_{w2} - t_{w1}) \quad (\text{F.1})$$

F.5.2 The water side heat exchange capacity of heating coil shall be calculated according to the Formula (F.2):

$$Q_w = WC_{pw}(t_{w1} - t_{w2}) \quad (\text{F.2})$$

F.5.3 The heat exchange capacity of steam heating shall be calculated according to the Formula (F.3):

$$Q_w = W(I_{v1} - I_{v2}) \quad (\text{F.3})$$

F.5.4 The cooling performance of water spraying section shall be calculated according to the Formula (F.4):

$$Q_w = W_2(t_{w2} - t_L) \quad (\text{F.4})$$

F.5.5 The test results shall be checked according to the calculation value of unit hand sample coil test, and the deviation shall be within -15% (see Formula (F.5)).

$$\frac{Q_w}{Q} = 100\% \pm 15\% \quad (\text{F.5})$$

Where:

Q_w the heat exchange capacity of water side or steam side of testing units, kW;

Q the calculation value of hand sample coil test, kW;

W the water flow of coil or devaporation water flow, kg/s;

C_{pw} the water specific heat at constant pressure, kJ may adopting

t_{w1}, t_{w2} the inlet/outlet water temperature of testing units,

I_{v1}, I_{v2} the inlet/outlet enthalpy value of vapor of testing units, kJ/kg;

W_2 the return water flow of water spraying section of testing units, kg/s;

t_L the chilled water supply temperature of water spraying section,